



**BIOPSY FORCEPS**  
 D'Amico Biopsy Forceps..... 7.2  
 D'Amico Mediastinoscopy Biopsy Forceps..... 7.3

**CLAMPS**  
 Rocco Nodule Clamp .....7.4  
 Gonzalez-Rivas Lung Grasping Clamp.....7.5  
 Foerster ..... 7.6  
 Duval ..... 7.11  
 Node Grasper ..... 7.12  
 Kahn Decortication Grasper.....7.13  
 Gonzalez-Rivas Dissector.....7.14  
 Gening J SPH Snake™ Dissector .....7.15  
 Dennis Dissector.....7.16  
 DeBakey Cooley Clamps .....7.17  
 Harken ..... 7.18  
 Allis Forceps.....7.19  
 D'Amico DeBakey Clamps.....7.20  
 Chitwood DeBakey Clamps .....7.21

**SCISSORS**  
 Super Cut™ Chitwood Handle..... 7.25

**FORCEPS**  
 Axial Handle..... 7.27  
 Rocco Adventitia Elevator .....7.29  
 Spring Style..... 7.29

**NEEDLE HOLDERS**  
 Spring Style..... 7.30  
 Ring Handle ..... 7.31  
 Axial Handle..... 7.35

**SPECIALTY**  
 Gonzalez-Rivas Knot Pusher .....7.37  
 Chitwood Knot Tier / Pusher..... 7.38  
 Chitwood Suture Cutter..... 7.39  
**Suction Instruments**  
 Wolf ..... 7.40  
 Dennis ..... 7.41  
 D'Amico ..... 7.42  
 Suction Accessories .....7.43  
 Dennis Rib Cutter .....7.44  
 Periosteal Elevator.....7.45  
 Stern™ Chest Tube Passer .....7.46  
 Chitwood Suture Puller .....7.47



Modification	Description
904	Angle jaws/tips
904A	Angle and cut down jaws/tips
905	Cut down jaws/tips
905B	Cut down scissors blades
905TC	Cut down carbon inlay jaws/tips
907	Angled shanks - down
907B	Angled shanks - up
912	Blunt tips of scissors
912A	Sharpen tips of scissors
915	Gold plating
924	Tension modification
928	Modify to left-handed instrument (ring style)
928A	Modify to left-handed instrument (spring style)
929	Special etching
965	Remove ratchets on ring handle instruments
979	Add ratchet to instrument (spring style)



**Example 1**  
9909-926  
Modified to have Ratchets Removed



**Example 2**  
9909-912-13  
Modified to have Jaws Angled and  
Shanks Angled Down

**Please Note...**

Each Scanlan instrument is individually handcrafted to provide the surgeon with the highest quality, longest-lasting, precision instrument possible. Reflecting this unique process, all stated dimensions are approximate.

# VATS/MIS Length Selections

## Shorter Length

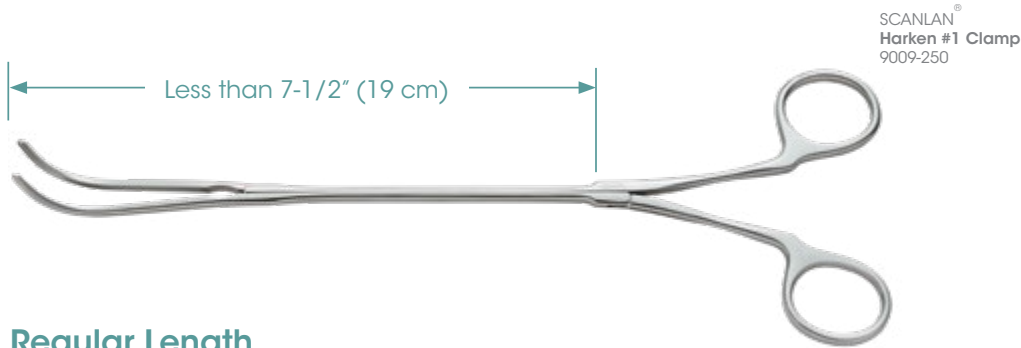

## Regular Length

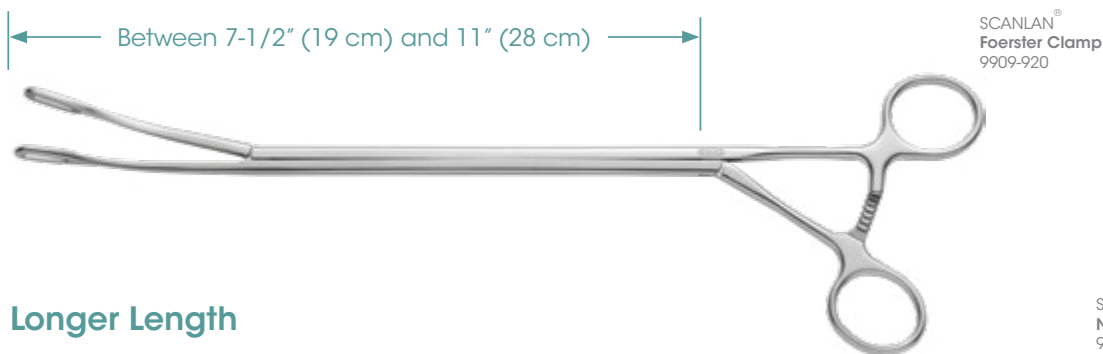

## Longer Length

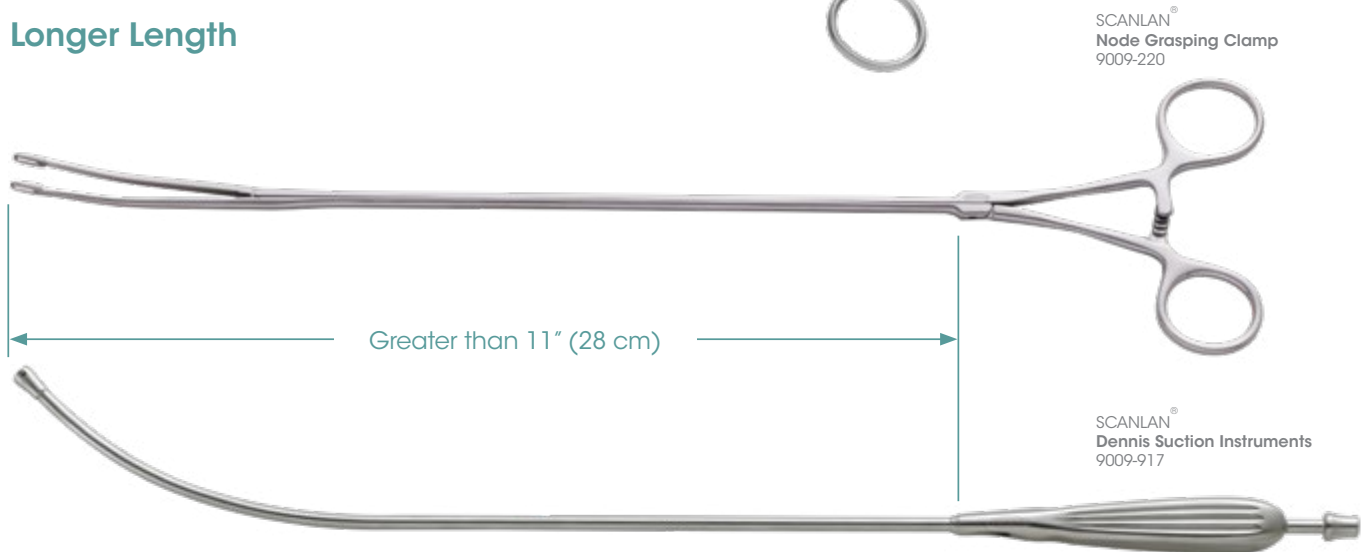

Please Note...  
Each Scanlan instrument is individually handcrafted to provide the surgeon with the highest quality, longest-lasting, precision instrument possible.  
Reflecting this unique process, all stated dimensions are approximate.

Please check with your Scanlan Representative for Firm Sale status. Custom modifications available upon request.  
For a complete listing of models visit... [www.scanlaninternational.com](http://www.scanlaninternational.com)



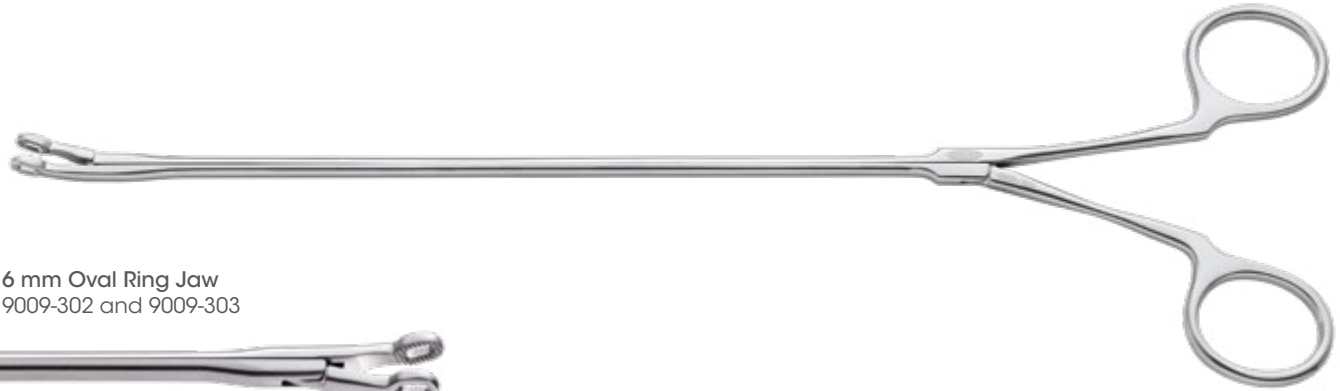

6 mm Oval Ring Jaw  
9009-302 and 9009-303



7 mm Oval Cupped Jaws  
9009-312 and 9009-313



SCANLAN®  
**D'Amico Biopsy Forceps, Ring Handle, Shorter Length**

Developed in cooperation with Thomas A. D'Amico, MD

Cat. No.	Description	Shaft	Working Length	Total Length
9009-302	6 mm Width Oval Ring Jaws Curved With Ratchet	5 mm Tapered to 7 mm	9" (23 cm)	13" (33 cm)
9009-303	6 mm Width Oval Ring Jaws Curved Without Ratchet			
9009-312	7 mm Width Oval Cupped Jaws Curved With Ratchet			
9009-313	7 mm Width Oval Cupped Jaws Curved Without Ratchet			

Please Note...

Each Scanlan instrument is individually handcrafted to provide the surgeon with the highest quality, longest-lasting, precision instrument possible. Reflecting this unique process, all stated dimensions are approximate.

# Mediastinoscopy Forceps

9009-301

VATS / MIS



6 mm Oval Ring Jaws  
9009-300 and 9009-301



7 mm Oval Cupped Jaws  
9009-310 and 9009-311

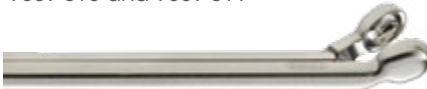

**VATS** SCANLAN®  
**D'Amico Mediastinoscopy Forceps**  
Developed in cooperation with Thomas A. D'Amico, MD

Cat. No.	Description	Shaft	Working Length	Total Length
9009-300	6 mm Width Oval Ring Jaws Curved With Ratchet	7 mm	11" (28 cm)	15" (38 cm)
9009-301	6 mm Width Oval Ring Jaws Curved Without Ratchet			
9009-310	7 mm Width Oval Cupped Jaws Curved With Ratchet			
9009-311	7 mm Width Oval Cupped Jaws Curved Without Ratchet			

Please check with your Scanlan Representative for Firm Sale status. Custom modifications available upon request.  
For a complete listing of models visit... [www.scanlaninternational.com](http://www.scanlaninternational.com)



# Rocco Nodule Clamp

VATS / MIS

9909-946



3.0 cm inner diameter and 3.7 cm outer diameter  
9909-946



4.5 cm inner diameter and 5.2 cm outer diameter  
9909-947

**SCANLAN®**  
**VATS Rocco Nodule Clamps**  
 Developed in cooperation with Gaetano Rocco, MD, FRCSEd, FEBTS, FCCP

Cat. No.	Description	Suggested Nodule Size*	Shaft	Working Length	Total Length
9909-946	Curved left ring jaws 3.0 cm inner diameter and 3.7 cm outer diameter with ratchet	Up to 1 cm	10 mm	9 1/2" (24 cm)	13 1/4" (33.5 cm)
9909-947	Curved left ring jaws 4.5 cm inner diameter and 5.2 cm outer diameter with ratchet	Between 1 and 1.5 cm			

\*Suggested Nodule Size per Gaetano Rocco, MD, FRCSEd, FEBTS, FCCP

**Please Note...**

Each Scanlan instrument is individually handcrafted to provide the surgeon with the highest quality, longest-lasting, precision instrument possible. Reflecting this unique process, all stated dimensions are approximate.



# Gonzalez-Rivas Lung Grasping Clamp

9009-230

VATS / MIS



9009-230

SCANLAN®  
**VATS Gonzalez-Rivas Lung Grasping Clamp**  
 Developed in cooperation with Diego Gonzalez-Rivas, MD, FECTS

Cat. No.	Description	Shaft	Working Length	Total Length
9009-230	High tension Curved left 20 mm oval ring jaws With ratchet	7 mm Tapered to 10 mm	5 3/4" (14.5 cm)	9 3/4" (24.5 cm)

Please check with your Scanlan Representative for Firm Sale status. Custom modifications available upon request.  
 For a complete listing of models visit... [www.scanlaninternational.com](http://www.scanlaninternational.com)



# Foerster Lung Grasping Clamp

VATS / MIS

9009-229



9009-229

9009-237

SCANLAN®  
**VATS Foerster Lung Grasping Clamp**

Cat. No.	Description	Shaft	Working Length	Total Length
9009-229	Curved left 20 mm oval ring jaws with ratchet	5 mm Tapered to 7 mm	9 1/4" (23.5 cm)	13 1/4" (33.5 cm)
9009-237			12 1/2" (32 cm)	16 1/2" (41.9 cm)

**Please Note...**

Each Scanlan instrument is individually handcrafted to provide the surgeon with the highest quality, longest-lasting, precision instrument possible. Reflecting this unique process, all stated dimensions are approximate.

Please check with your Scanlan Representative for Firm Sale status. Custom modifications available upon request.

For a complete listing of models visit... [www.scanlaninternational.com](http://www.scanlaninternational.com)



# Foerster Lung Grasping Clamp

9009-227

VATS / MIS



Curved Left  
12 mm Oval Ring Jaws  
9009-228



Curved Right  
(Left-Hand Style)  
12 mm Oval Ring Jaws  
9009-227



Curved Left  
20 mm Oval Ring Jaws  
9909-922



Curved Right  
20 mm Oval Ring Jaws  
9909-921

**SCANLAN®**  
VATS Foerster Lung Grasping Clamp

Cat. No.	Description	Shaft	Working Length	Total Length
9009-227	Curved Right Jaws (Left-Hand Style) 12 mm Oval Ring Jaws With Ratchet	7 mm	7 1/2" (19 cm)	11 1/2" (29 cm)
9009-228	Curved Left Jaws 12 mm Oval Ring Jaws With ratchet			
9909-921	Curved Right (Left-Hand Style) 20 mm Oval Ring Jaws With Ratchet	10 mm		
9909-922	Curved Left 20 mm Oval Ring Jaws With Ratchet			



# Foerster Lung Grasping Clamp

VATS / MIS

9009-226



SCANLAN®  
**VATS** Foerster Lung Grasping Clamp

Cat. No.	Description	Shaft	Working Length	Total Length
9009-226	Curved left jaws 12 mm oval ring jaws With ratchet	7 mm	9 1/4" (23.5 cm)	13 1/4" (33.5 cm)

**Please Note...**

Each Scanlan instrument is individually handcrafted to provide the surgeon with the highest quality, longest-lasting, precision instrument possible. Reflecting this unique process, all stated dimensions are approximate.

# Foerster Lung Grasping Clamp

9909-923

VATS / MIS



9909-923



9909-919



**VATS** SCANLAN®  
**Foerster Lung Grasping Clamp**

Cat. No.	Description	Shaft	Working Length	Total Length
9909-923	Deep curved left jaws 20 mm oval ring jaws With ratchet	10 mm	9 1/2" (24 cm)	13" (33 cm)
9909-919	Deep curved left jaws 20 mm oval ring jaws With ratchet		12 1/2" (32 cm)	16 3/4" (42.4 cm)

Please check with your Scanlan Representative for Firm Sale status. Custom modifications available upon request.  
For a complete listing of models visit... [www.scanlaninternational.com](http://www.scanlaninternational.com)



# Foerster Lung Grasping Clamp

VATS / MIS

9909-920



9909-920  
9909-920-1



9909-925



9909-924

**VATS** SCANLAN®  
Foerster Lung Grasping Clamp

Cat. No.	Description	Shaft	Working Length	Total Length
9909-920	Curved left jaws 20 mm oval ring jaws With ratchet	10 mm	9 1/2" (24 cm)	13 1/4" (33.5 cm)
<b>NEW</b> 9909-920-1	Curved left jaws 20 mm oval ring jaws Without ratchet			
9909-925	Curved left jaws 20 mm oval ring jaws With ratchet		12 1/2" (32 cm)	16 3/4" (42.4 cm)
9909-924	Curved left jaws 25 x 35 mm oval ring jaws With ratchet		9 1/2" (24 cm)	13 1/4" (33.5 cm)

# Duval Lung Grasping Clamp

9909-926

VATS / MIS



9909-926  
9909-928



9909-927

**VATS** SCANLAN®  
**Duval Lung Grasping Clamp**

Cat. No.	Description	Shaft	Working Length	Total Length
9909-926	Curved left jaws 1.0 cm width triangular ring jaws With ratchet	10 mm	9 1/4" (23.5 cm)	13 1/2" (34 cm)
9909-928			12 1/2" (32 cm)	16 3/4" (42.4 cm)
9909-927	Curved left jaws 2.5 cm width triangular ring jaws With ratchet		9 1/4" (23.5 cm)	13 1/2" (34 cm)

Please Note...  
Each Scanlan instrument is individually handcrafted to provide the surgeon with the highest quality, longest-lasting, precision instrument possible.  
Reflecting this unique process, all stated dimensions are approximate.

Please check with your Scanlan Representative for Firm Sale status. Custom modifications available upon request.  
For a complete listing of models visit... [www.scanlaninternational.com](http://www.scanlaninternational.com)



SCANLAN®  
Node Grasping Clamp

VATS / MIS

9009-223



9009-222

9009-223  
9009-225  
9009-220  
9009-221  
9009-290

VATS SCANLAN®  
Node Grasping Clamp

Cat. No.	Description	Shaft	Working Length	Total Length
9009-222	Straight jaws 11 mm oblong ring jaws With ratchet	5 mm	9" (23 cm)	13" (33 cm)
9009-223	Curved jaws 11 mm oblong ring jaws With ratchet			
9009-225	Curved jaws 11 mm oblong ring jaws Without ratchet			
<b>NEW</b> 9009-290	<b>Thoroscopic Grasping Dissector</b> Curved jaws 11 mm oblong ring jaws With ratchet <i>NOTE: Ratchets are tuned to engage after jaws meet.</i>			
9009-220	Curved jaws 11 mm oblong ring jaws With ratchet	5 mm Tapered to 7 mm	12 1/2" (32 cm)	16 3/4" (42.4 cm)
9009-221	Curved jaws 11 mm oblong ring jaws Without ratchet			

# Khan Decortication Grasper

9909-940

VATS / MIS



9909-940



SCANLAN®

## Khan Decortication Grasper Clamp

Developed in cooperation with Prof. Ali Zamir Khan, MS, FRCS(Glasg), FRCS(CTh), FEBTS, MBA

Cat. No.	Description	Shaft	Working Length	Total Length
9909-940	Enhanced serrations Curved left jaws With ratchet	10 mm	9 1/2" (24 cm)	13 1/4" (33.5 cm)

### Kahn Decortication Grasper Jaws Compared to Foerster Clamp Jaws

9909-940  
Khan Decortification Grasper



9909-920  
Foerster Lung Clamp



Please Note...  
Each Scanlan instrument is individually handcrafted to provide the surgeon with the highest quality, longest-lasting, precision instrument possible.  
Reflecting this unique process, all stated dimensions are approximate.

Please check with your Scanlan Representative for Firm Sale status. Custom modifications available upon request.  
For a complete listing of models visit... [www.scanlaninternational.com](http://www.scanlaninternational.com)



# Gonzalez-Rivas Dissector

VATS / MIS

9009-211



1 x 2 DeBakey Jaws  
9009-210, 9009-211, 9009-214, 9009-215, 9009-216, 9009-217



1 x 2 DeBakey Jaws Fine Tips  
9009-212 and 9009-213



**VATS** SCANLAN®  
**Gonzalez-Rivas Dissector**  
Developed in cooperation with Diego Gonzalez-Rivas, MD, FECTS

Cat. No.	Description	Shaft	Working Length	Total Length
9009-210	Mixer-style 1 x 2 DeBakey jaws With ratchet	5 mm	7 1/2" (19 cm)	11 1/2" (29 cm)
9009-211	Mixer-style 1 x 2 DeBakey jaws Without ratchet			
9009-212	Mixer-style 1 x 2 DeBakey jaws fine tips With ratchet			
9009-213	Mixer-style 1 x 2 DeBakey jaws fine tips Without ratchet			
9009-214	Mixer-style 1 x 2 DeBakey jaws With ratchet	5 mm to 7 mm Tapered	9 1/2" (24 cm)	13 1/2" (34 cm)
9009-215	Mixer-style 1 x 2 DeBakey jaws Without ratchet			
9009-216	Mixer-style 1 x 2 DeBakey jaws With ratchet	5 mm to 7 mm Tapered	12 1/2" (32 cm)	16 1/2" (41.9 cm)
9009-217	Mixer-style 1 x 2 DeBakey jaws Without ratchet			



# Gening J SPH Snake™ Dissector

9009-284

VATS / MIS



**VATS** SCANLAN®  
**Gening J SPH Snake™ Dissector**  
 Developed in cooperation with Gening Jiang, MD

Cat. No.	Description	Shaft	Working Length	Total Length
<b>NEW</b> 9009-284	Curved dissector jaws With ratchet	5 mm Tapered To 7 mm	9 1/4" (23.5 cm)	13 1/2" (34 cm)
<b>NEW</b> 9009-285	Curved dissector jaws Without ratchet			
<b>NEW</b> 9009-286	Curved dissector jaws With ratchet		12 1/2" (32 cm)	16 3/4" (42.4 cm)
<b>NEW</b> 9009-287	Curved dissector jaws Without ratchet			

Please Note...  
 Each Scanlan instrument is individually handcrafted to provide the surgeon with the highest quality, longest-lasting, precision instrument possible.  
 Reflecting this unique process, all stated dimensions are approximate.

Please check with your Scanlan Representative for Firm Sale status. Custom modifications available upon request.  
 For a complete listing of models visit... [www.scanlaninternational.com](http://www.scanlaninternational.com)



# Dennis Dissector

VATS / MIS

9009-280

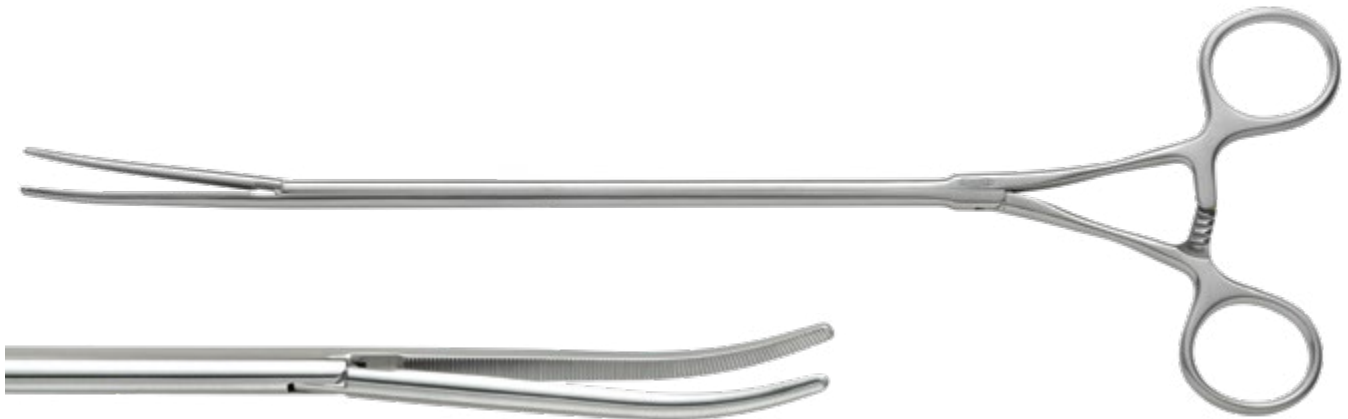

Curved Jaws  
9009-280 and 9009-281



Cat. No.	Description	Shaft	Working Length	Total Length
9009-280	Curved left jaws Serrated jaws With ratchet	7 mm	9" (23 cm)	13 1/4" (33.5 cm)
9009-281	Curved left jaws Serrated jaws Without ratchet			
9009-282	Curved left jaws Serrated jaws With ratchet	5 mm Tapered To 7 mm	12.50" (32 cm)	16 3/4" (42.4 cm)
9009-283	Curved left jaws Serrated jaws Without ratchet			

**Please Note...**

Each Scanlan instrument is individually handcrafted to provide the surgeon with the highest quality, longest-lasting, precision instrument possible. Reflecting this unique process, all stated dimensions are approximate.



# DeBakey Cooley Clamps

9909-203

VATS / MIS



90° Angled Jaws  
9909-202 and 9909-203

VATS MIS SCANLAN® DeBakey Cooley Clamps

Cat. No.	Description	Shaft	Working Length	Total Length
9909-202	DeBakey Cooley Jaws With Ratchet	10 mm	9 1/2" (24 cm)	13 1/2" (34 cm)
9909-203	DeBakey Cooley Jaws Without Ratchet			

Please check with your Scanlan Representative for Firm Sale status. Custom modifications available upon request.  
For a complete listing of models visit... [www.scanlaninternational.com](http://www.scanlaninternational.com)



# Harken Clamps

VATS / MIS

9909-224

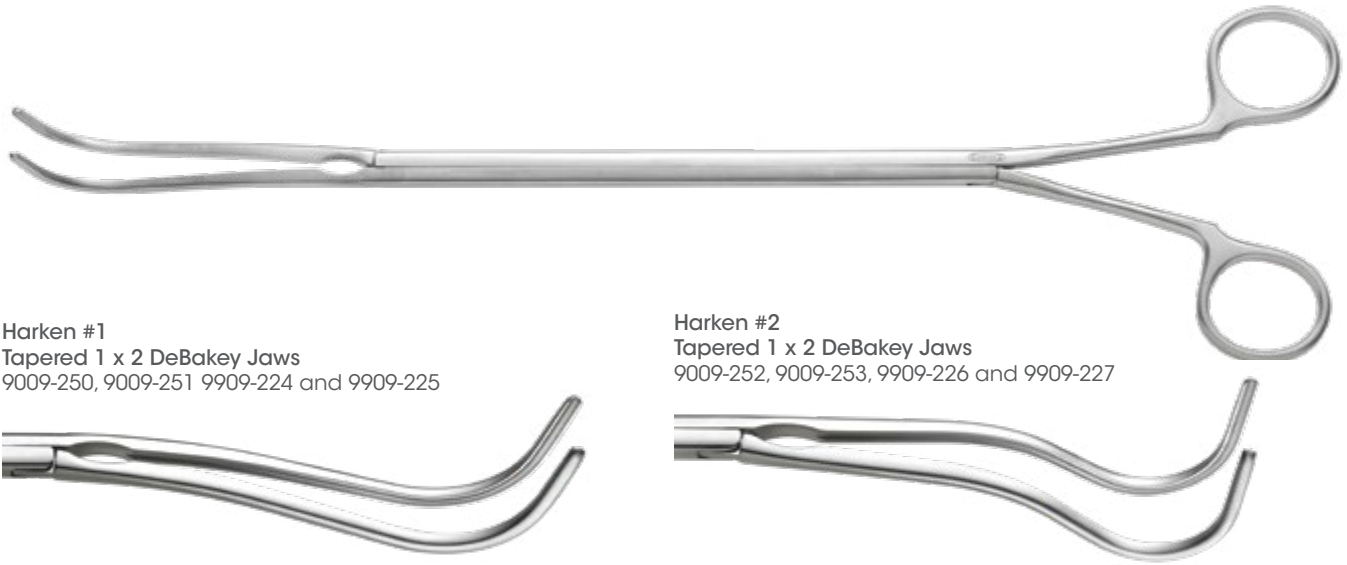

**Harken #1**  
Tapered 1 x 2 DeBakey Jaws  
9009-250, 9009-251 9909-224 and 9909-225

**Harken #2**  
Tapered 1 x 2 DeBakey Jaws  
9009-252, 9009-253, 9909-226 and 9909-227



Cat. No.	Description	Shaft	Working Length	Total Length
9009-250	7.5 cm jaws Tapered 1x2 DeBakey jaws Without ratchet	5 mm to 7 mm tapered	7 1/2" (19 cm)	11 1/2" (29 cm)
9009-251	7.5 cm jaws Tapered 1x2 DeBakey jaws With ratchet			
9009-252	7.5 cm jaws Tapered 1x2 DeBakey jaws Without ratchet			
9009-253	7.5 cm jaws Tapered 1x2 DeBakey jaws With ratchet			
9909-224	9.5 cm jaws Tapered 1x2 DeBakey jaws Without ratchet	10 mm	9 7/8" (25 cm)	14" (35.6 cm)
9909-225	9.5 cm jaws Tapered 1x2 DeBakey jaws With ratchet			
9909-226	9.5 cm jaws Tapered 1x2 DeBakey jaws Without ratchet			
9909-227	9.5 cm jaws Tapered 1x2 DeBakey jaws With ratchet			

# Allis Forceps (Clamp)

9009-270

VATS / MIS



9009-270

9009-274  
9009-275



Cat. No.	Description	Shaft	Working Length	Total Length
9009-270	Curved left jaws 6 mm width jaws With ratchet	7 mm	9" (23 cm)	13 1/4" (33.5 cm)
9009-274	Straight jaws 4 mm width jaws With ratchet	5 mm Tapered to 7 mm	7 1/2" (19 cm)	11 1/2" (29 cm)
9009-275	Curved left jaws 4 mm width jaws With ratchet			

Please Note...  
Each Scanlan instrument is individually handcrafted to provide the surgeon with the highest quality, longest-lasting, precision instrument possible.  
Reflecting this unique process, all stated dimensions are approximate.

Please check with your Scanlan Representative for Firm Sale status. Custom modifications available upon request.  
For a complete listing of models visit... [www.scanlaninternational.com](http://www.scanlaninternational.com)



# D'Amico DeBakey Clamps

VATS / MIS

9909-221



Curved 1 x 2 Tapered DeBakey Jaws  
9909-219 and 9909-221



D'Amico Tapered Jaw Tip  
Compared to  
Chitwood DeBakey Jaw Tip

9909-219 and 9909-221  
D'Amico curved tapered  
1 x 2 DeBakey jaws



Straight 1 x 2 Tapered DeBakey Jaws  
9909-222



9909-912-13  
Chitwood curved  
1 x 2 DeBakey jaws



SCANLAN®  
VATS **D'Amico DeBakey Clamps**  
Developed in cooperation with Thomas A. D'Amico, MD

Cat. No.	Description	Shaft	Working Length	Total Length
9909-219	Curved left jaws Tapered 1x2 DeBakey jaws 11cm jaw length Without ratchet	10 mm	10" (25.4 cm)	14 1/2" (37 cm)
9909-221	Curved left jaws Tapered 1x2 DeBakey jaws 11cm jaw length With ratchet			
9909-222	Straight jaws Tapered 1x2 DeBakey jaws 11.5 cm jaw length With ratchet		10 1/2" (27 cm)	14 3/4" (37.5 cm)

**Please Note...**

Each Scanlan instrument is individually handcrafted to provide the surgeon with the highest quality, longest-lasting, precision instrument possible. Reflecting this unique process, all stated dimensions are approximate.



# Chitwood DeBakey Clamps

9009-240

VATS / MIS



1 x 2 DeBakey Jaws  
9009-240 and 9009-241



**VATS** **MIS** SCANLAN®  
**Chitwood DeBakey Clamps**  
 Developed in cooperation with W. Randolph Chitwood Jr., MD

Cat. No.	Description	Shaft	Working Length	Total Length
9009-240	6 cm jaw length Curved left jaws 1 x 2 DeBakey jaws With ratchet	5 mm	8 1/4" (21 cm)	12 1/4" (31 cm)
9009-241	6 cm jaw length Curved left jaws 1 x 2 DeBakey jaws Without ratchet			

Please check with your Scanlan Representative for Firm Sale status. Custom modifications available upon request.  
 For a complete listing of models visit... [www.scanlaninternational.com](http://www.scanlaninternational.com)



# Chitwood DeBakey Clamps

VATS / MIS

9909-912-13



1 x 2 DeBakey Jaws  
9909-912



1 x 2 DeBakey Jaws  
9909-912-13



2 x 3 DeBakey Jaws  
9909-232



VATS
MIS
**SCANLAN®**  
**Chitwood DeBakey Clamps**  
 Developed in cooperation with W. Randolph Chitwood Jr., MD

Cat. No.	Description	Shaft	Working Length	Total Length
9909-912	6.5 cm jaw length 1x2 DeBakey jaws Curved left jaws With ratchet	10 mm	9" (23 cm)	12 3/4" (32.5 cm)
9909-912-13	10 cm jaw length 1x2 DeBakey jaws Curved left jaws With ratchet		10" (25.4 cm)	14 1/4" (36 cm)
9909-232	10 cm jaw length 2x3 DeBakey jaws Curved left jaws With ratchet			

**Please Note...**

Each Scanlan instrument is individually handcrafted to provide the surgeon with the highest quality, longest-lasting, precision instrument possible. Reflecting this unique process, all stated dimensions are approximate.





# Chitwood DeBakey Clamps

9909-914

VATS / MIS



1 x 2 DeBakey Jaws  
9909-915



1 x 2 DeBakey Jaws  
9909-914



VATS
MIS
**SCANLAN®**  
**Chitwood DeBakey Clamps**  
 Developed in cooperation with W. Randolph Chitwood Jr., MD

Cat. No.	Description	Shaft	Working Length	Total Length
9909-914	7 cm jaw length Curved left jaw 1x2 DeBakey jaws With ratchet	10 mm	6 3/4" (17 cm)	10 3/8" (26.4 cm)
9909-915	7 cm jaw length Curved right jaw 1x2 DeBakey jaws With ratchet			

Please check with your Scanlan Representative for Firm Sale status. Custom modifications available upon request.  
For a complete listing of models visit... [www.scanlaninternational.com](http://www.scanlaninternational.com)



# Chitwood DeBakey Clamps

VATS / MIS

9909-234



2 x 3 DeBakey Jaws  
9909-234

**MIS** SCANLAN®  
**Chitwood DeBakey Clamps**  
Developed in cooperation with W. Randolph Chitwood Jr., MD

Cat. No.	Description	Shaft	Working Length	Total Length
9909-234	8 cm jaw length Curved left jaws 2 x 3 DeBakey jaws Angled shanks	10 mm	5 1/8" (13 cm)	8" (20.5 cm)

9909-913



**MIS** SCANLAN®  
**Chitwood DeBakey Clamps**  
Developed in cooperation with W. Randolph Chitwood Jr., MD

Cat. No.	Description	Shaft	Working Length	Total Length
9909-913	7 cm jaw length Curved left jaws 1 x 2 DeBakey jaws Angled shanks	10 mm	6 3/4" (17 cm)	9 3/4" (24.8 cm)

9009-738SC

VATS / MIS

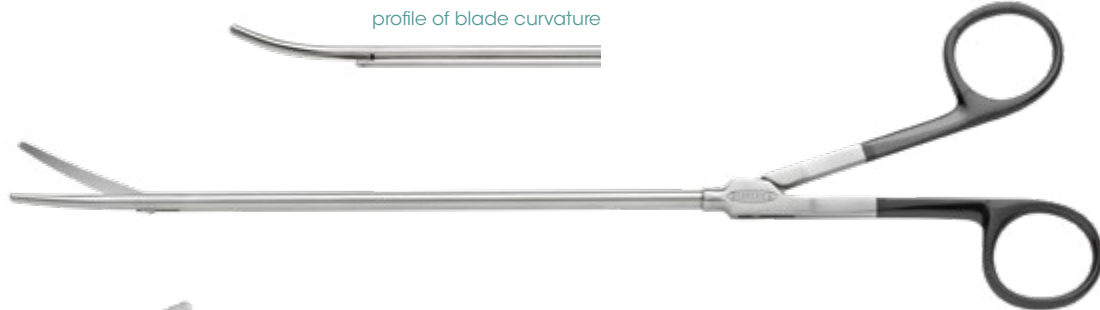

**Straight Fine Blades**  
9009-716SC



**Curved Blades**  
9009-718SC



**Curved Blades**  
9009-738SC



SCANLAN®  
**Chitwood Dissecting Scissors**  
Developed in cooperation with W. Randolph Chitwood Jr., MD

Cat. No.	Description	Shaft	Working Length	Total Length
9009-716SC	Straight fine blades 1 cm blade length Blunt micro tips	5 mm	6 1/2" (16.5 cm)	10 1/2" (27 cm)
9009-718SC	Curved Fine Blades 1 cm Blade Length Blunt Micro Tips		6 1/2" (16.5 cm)	10 1/2" (27 cm)
9009-738SC	Chitwood dissecting scissors Curved blades 3 cm blade length Blunt tips		7 1/4" (18.5 cm)	11 1/2" (29 cm)

Please Note...  
Each Scanlan instrument is individually handcrafted to provide the surgeon with the highest quality, longest-lasting, precision instrument possible.  
Reflecting this unique process, all stated dimensions are approximate.

Please check with your Scanlan Representative for Firm Sale status. Custom modifications available upon request.  
For a complete listing of models visit... [www.scanlaninternational.com](http://www.scanlaninternational.com)



# Super Cut™ Scissors

VATS / MIS

9009-710SC



**VATS** **MIS** SCANLAN®  
Metzenbaum Scissors

Cat. No.	Description	Shaft	Working Length	Total Length
9009-710SC	Curved blades 3.1 cm blade length Blunt tips	8 mm	12 1/2" (32 cm)	16 1/2" (42.1 cm)

9909-911SC

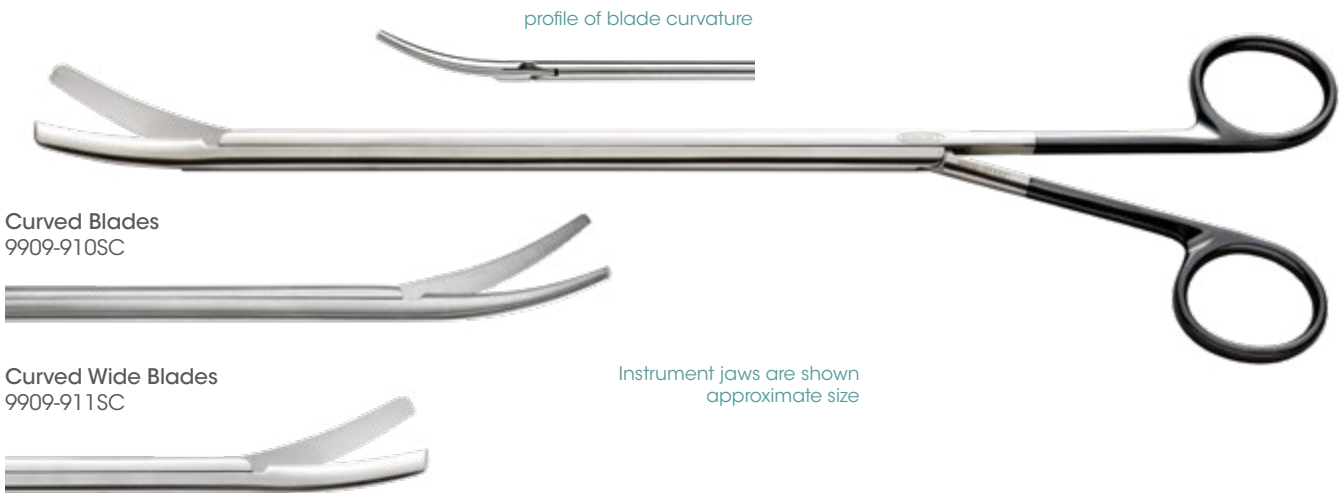

Curved Blades  
9909-910SC

Curved Wide Blades  
9909-911SC

Instrument jaws are shown  
approximate size

**VATS** SCANLAN®  
Metzenbaum Scissors

Cat. No.	Description	Shaft	Working Length	Total Length
9909-910SC	Curved blades 3.5 cm blade length Blunt tips	10 mm	7 3/4" (19.5 cm)	11 1/2" (29 cm)
9909-911SC	Curved wide blades 3.5 cm blade length Blunt tips			

**Please Note...**

Each Scanlan instrument is individually handcrafted to provide the surgeon with the highest quality, longest-lasting, precision instrument possible. Reflecting this unique process, all stated dimensions are approximate.

# Gonzalez-Rivas Forceps

9009-530

VATS / MIS



Curved DeBakey Jaws, 2.5 mm Width  
9009-530

**VATS** SCANLAN®  
**Gonzalez-Rivas Forceps**  
Developed in cooperation with Diego Gonzalez-Rivas, MD, FECTS

Cat. No.	Description	Shaft	Working Length	Total Length
9009-530	8 mm diamond knurling 2.5 mm width curved DeBakey jaws without ratchet	5 mm	6 3/8" (16.2 cm)	12 3/4" (32.5 cm)
9009-532			8" (20 cm)	14-3/8" (36.5 cm)

# Axial Handle Forceps

9009-528



DeBakey Jaws, 2.5 mm Width  
9009-528

Instrument jaws are shown  
approximate size

**VATS** **MIS** SCANLAN®  
**Axial Handle Forceps**  
Round Handle | 8 mm Diameter Knurling

Cat. No.	Description	Shaft	Working Length	Total Length
9009-528	2.5 mm width DeBakey jaws Without ratchet	5 mm	6 1/4" (16 cm)	12 1/2" (32 cm)

Please check with your Scanlan Representative for Firm Sale status. Custom modifications available upon request.  
For a complete listing of models visit... [www.scanlaninternational.com](http://www.scanlaninternational.com)



# Axial Handle Forceps

VATS / MIS

9009-524



Resano Jaws, 2.5 mm Width  
9009-510 and 9009-511



Russian Jaws, 6 mm Width  
9009-512 and 9009-513



Platform DIAMOND DUST™, 2 mm Width  
9009-516 and 9009-517



DeBakey Jaws, 1.5 mm Width  
9009-520 and 9009-521



DeBakey Jaws, 2.5 mm Width  
9009-522 and 9009-523



DeBakey Jaws, 3.5 mm Width  
9009-524 and 9009-525



VATS
MIS
**SCANLAN®**  
**Axial Handle Forceps**  
 Round Handle | 10 mm Diameter Knurling

Cat. No.	Description	Shaft	Working Length	Total Length
9009-510	2.5 mm width Resano jaws Without ratchet	5 mm	8" (20 cm)	14 1/4" (36 cm)
9009-511	2.5 mm width Resano jaws With ratchet			
9009-512	6 mm width Russian jaws Without ratchet			
9009-513	6 mm width Russian jaws With ratchet			
9009-516	2 mm width Platform DIAMOND DUST™ jaws Without ratchet			
9009-517	2 mm width Platform DIAMOND DUST™ jaws With ratchet			
9009-520	1.5 mm width DeBakey jaws Without ratchet			
9009-521	1.5 mm width DeBakey jaws With ratchet			
9009-522	2.5 mm width DeBakey jaws Without ratchet			
9009-523	2.5 mm width DeBakey jaws With ratchet			
9009-524	3.5 mm width DeBakey jaws Without ratchet			
9009-525	3.5 mm width DeBakey jaws With ratchet			

Please Note...

Each Scanlan instrument is individually handcrafted to provide the surgeon with the highest quality, longest-lasting, precision instrument possible. Reflecting this unique process, all stated dimensions are approximate.



# Rocco Adventitia Elevator (Forceps)

9009-500

VATS / MIS



9009-500



SCANLAN®

## Rocco Adventitia Elevator (Forceps)

Developed in cooperation with Gaetano Rocco, MD, FRCsed, FETCS, FCCP

Cat. No.	Description	Shaft	Working Length	Total Length
9009-500	DIAMOND DUST™ Jaws Curved Down Without Ratchet Ring Handle Curved Down	5 mm	8" (20 cm)	12 3/4" (32.5 cm)

SCANLAN®

# Spring Style Forceps

9009-422



DeBakey Jaws, 1 mm Width  
9009-420

DeBakey Jaws, 2 mm Width  
9009-422



SCANLAN®

## Jacobson Spring Style Forceps

Round Handle | 8 mm Diameter Knurling

Cat. No.	Description	Shaft	Working Length	Total Length
9009-420	1 mm width straight DeBakey jaws Without ratchet	5 mm	7 3/4" (19.5 cm)	16" (41 cm)
9009-422	2 mm width straight DeBakey jaws Without ratchet			

Please check with your Scanlan Representative for Firm Sale status. Custom modifications available upon request.  
For a complete listing of models visit... [www.scanlaninternational.com](http://www.scanlaninternational.com)



# Spring Style Needle Holders

VATS / MIS

9009-648



Straight DIAMOND DUST™ Jaws,  
for 5-0 Suture  
9009-648

Curved DIAMOND DUST™ Jaws,  
for 5-0 Suture  
9009-650



Instrument jaws are shown  
approximate size



SCANLAN®

## Jacobson Spring Style Needle Holders

Round Handle | 8 mm Diameter Knurling

Cat. No.	Description	Suture Size	Shaft	Working Length	Total Length
9009-648	Straight DIAMOND DUST™ Jaws With Ratchet	5-0 and Smaller	5 mm	6 1/2" (16.5 cm)	15 3/8" (38.5 cm)
9009-650	Curved DIAMOND DUST™ Jaws With Ratchet				

**Please Note...**

Each Scanlan instrument is individually handcrafted to provide the surgeon with the highest quality, longest-lasting, precision instrument possible. Reflecting this unique process, all stated dimensions are approximate.





# Ring Handle Needle Holders

9009-618

VATS / MIS

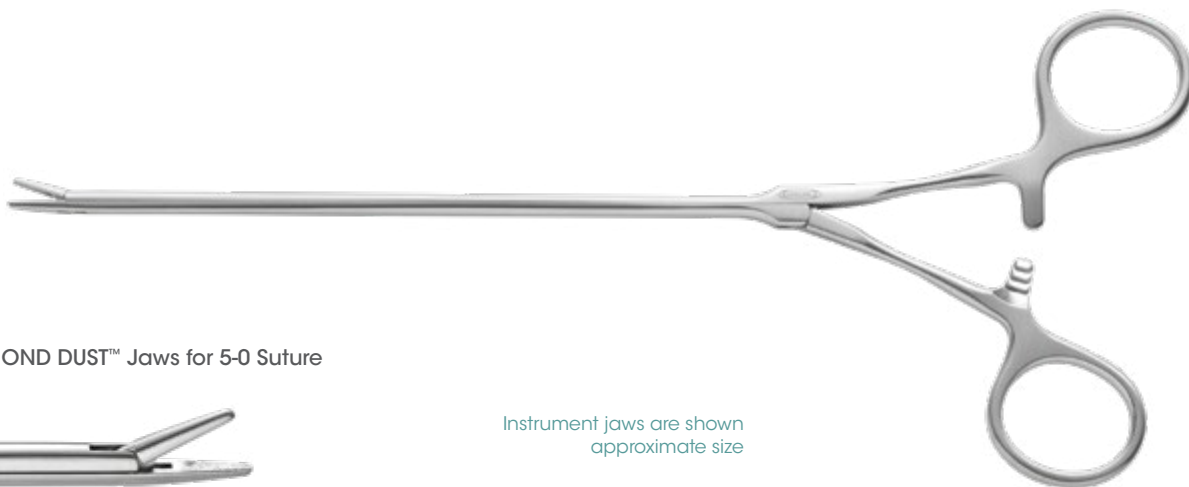

Straight DIAMOND DUST™ Jaws for 5-0 Suture  
9009-618



Instrument jaws are shown  
approximate size

VATS MIS SCANLAN®  
Ring Handle Needle Holders

Cat. No.	Description	Suture Size	Shaft	Working Length	Total Length
9009-618	Straight jaws Fine DIAMOND DUST™ jaws With ratchet	5-0 and Smaller	5 mm	6 1/2" (16.5 cm)	10 1/2" (27 cm)

Please check with your Scanlan Representative for Firm Sale status. Custom modifications available upon request.  
For a complete listing of models visit... [www.scanlaninternational.com](http://www.scanlaninternational.com)



# Ring Handle Needle Holders

VATS / MIS

9009-638

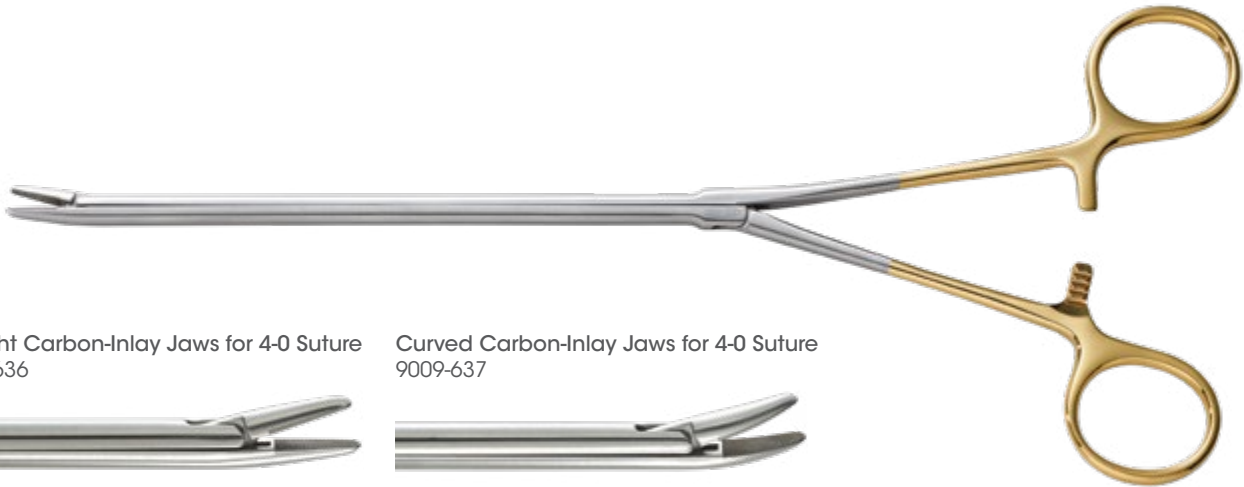

Straight Carbon-Inlay Jaws for 4-0 Suture  
9009-636



Curved Carbon-Inlay Jaws for 4-0 Suture  
9009-637



Straight Carbon-Inlay Jaws for 2-0 Suture  
9009-638



Curved Carbon-Inlay Jaws for 2-0 Suture  
9009-639



Instrument jaws are shown approximate size



SCANLAN®  
Ring Handle Needle Holders

Cat. No.	Description	Suture Size	Shaft	Working Length	Total Length
9009-636	Straight jaws Carbon-inlay jaws Gold ring handle With ratchet	4-0 and Smaller	7 mm	6 1/4" (16 cm)	11 1/4" (28.5 cm)
9009-637	Curved jaws Carbon-inlay jaws Gold ring handle With ratchet				
9009-638	Straight jaws Carbon-inlay jaws Gold ring handle With ratchet	2-0 and Smaller			
9009-639	Curved jaws Carbon-inlay jaws Gold ring handle With ratchet				

**Please Note...**

Each Scanlan instrument is individually handcrafted to provide the surgeon with the highest quality, longest-lasting, precision instrument possible. Reflecting this unique process, all stated dimensions are approximate.

Please check with your Scanlan Representative for Firm Sale status. Custom modifications available upon request.

For a complete listing of models visit... [www.scanlaninternational.com](http://www.scanlaninternational.com)



# Ring Handle Needle Holders

9009-644



Straight Carbon-Inlay Jaws for 2-0 Suture  
9009-644

Curved Carbon-Inlay Jaws for 2-0 Suture  
9009-645

VATS / MIS

VATS MIS SCANLAN®  
Ring Handle Needle Holders

Cat. No.	Description	Suture Size	Shaft	Working Length	Total Length
9009-644	Straight jaws Carbon-inlay jaws Gold ring handle With ratchet	2-0 and Smaller	7 mm	12 1/2" (32 cm)	17 1/2" (44.5 cm)
9009-645	Curved jaws Carbon-inlay jaws Gold ring handle With ratchet				

9009-640



Straight Carbon-Inlay Jaws for 4-0 Suture  
9009-640

Curved Carbon-Inlay Jaws for 4-0 Suture  
9009-642

VATS MIS SCANLAN®  
Ring Handle Needle Holders

Cat. No.	Description	Suture Size	Shaft	Working Length	Total Length
9009-640	Straight jaws Carbon-inlay jaws Gold ring handle With ratchet	4-0 and Smaller	7 mm	8 1/2" (21.5 cm)	13 1/2" (34 cm)
9009-642	Curved jaws Carbon-inlay jaws Gold ring handle With ratchet				



# Ring Handle Needle Holders

VATS / MIS

9909-610

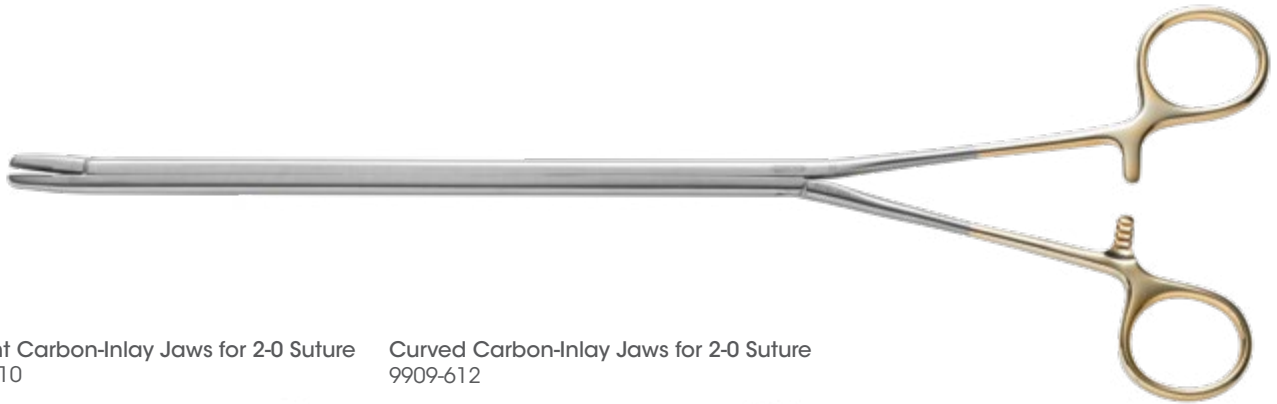

Straight Carbon-Inlay Jaws for 2-0 Suture  
9909-610

Curved Carbon-Inlay Jaws for 2-0 Suture  
9909-612



**VATS** **MIS** SCANLAN®  
Ring Handle Needle Holders

Cat. No.	Description	Suture Size	Shaft	Working Length	Total Length
9909-610	Straight jaws Carbon-inlay jaws Gold ring handle With ratchet	2-0 and Smaller	10 mm	8 1/4" (21 cm)	13 1/2" (34 cm)
9909-612	Curved jaws Carbon-inlay jaws Gold ring handle With ratchet				

**Please Note...**

Each Scanlan instrument is individually handcrafted to provide the surgeon with the highest quality, longest-lasting, precision instrument possible. Reflecting this unique process, all stated dimensions are approximate.

# Axial Handle Needle Holders

9009-541

VATS / MIS



Straight DIAMOND DUST™  
Jaws, for 7-0 Suture  
9009-540 and 9009-541

Curved DIAMOND DUST™  
Jaws, for 7-0 Suture  
9009-542 and 9009-543

Straight DIAMOND DUST™  
Jaws, for 5-0 Suture  
9009-550 and 9009-551

Curved DIAMOND DUST™  
Jaws, for 5-0 Suture  
9009-552 and 9009-553



SCANLAN®  
Axial Handle Needle Holders

Cat. No.	Description	Suture Size	Shaft	Working Length	Total Length
9009-540	Straight DIAMOND DUST™ Jaws Without ratchet	7-0 and Smaller	5 mm	8" (20 cm)	14 3/8" (36.5 cm)
9009-541	Straight DIAMOND DUST™ Jaws With ratchet				
9009-542	Curved DIAMOND DUST™ Jaws Without ratchet				
9009-543	Curved DIAMOND DUST™ Jaws With ratchet				
9009-550	Straight DIAMOND DUST™ Jaws Without ratchet	5-0 and Smaller	6 mm	8" (20 cm)	14 3/8" (36.5 cm)
9009-551	Straight DIAMOND DUST™ Jaws With ratchet				
9009-552	Curved DIAMOND DUST™ Jaws Without ratchet				
9009-553	Curved DIAMOND DUST™ Jaws With ratchet				

Please check with your Scanlan Representative for Firm Sale status. Custom modifications available upon request.  
For a complete listing of models visit... [www.scanlaninternational.com](http://www.scanlaninternational.com)



# Axial Handle Needle Holders

VATS / MIS

9009-571



Straight Carbon-Inlay Jaws,  
for 2-0 Suture  
9009-570 and 9009-571

Curved Carbon-Inlay Jaws,  
for 2-0 Suture  
9009-572 and 9009-573

Straight Carbon-Inlay Jaws,  
for 4-0 Suture  
9009-560 and 9009-561

Curved Carbon-Inlay Jaws,  
for 4-0 Suture  
9009-562 and 9009-563



Cat. No.	Description	Suture Size	Shaft	Working Length	Total Length
9009-570	Straight Carbon-inlay jaws Gold tipped handle Without ratchet	2-0 and Smaller	7 mm	8" (20 cm)	14 3/8" (36.5 cm)
9009-571	Straight Carbon-inlay jaws Gold tipped handle With ratchet				
9009-572	Curved Carbon-inlay jaws Gold tipped handle Without ratchet				
9009-573	Curved Carbon-inlay jaws Gold tipped handle With ratchet				
9009-560	Straight Carbon-inlay jaws Gold tipped handle Without ratchet	4-0 and Smaller	7 mm	8" (20 cm)	14 3/8" (36.5 cm)
9009-561	Straight Carbon-inlay jaws Gold tipped handle With ratchet				
9009-562	Curved Carbon-inlay jaws Gold tipped handle Without ratchet				
9009-563	Curved Carbon-inlay jaws Gold tipped handle With ratchet				

9009-826-14

VATS / MIS



**VATS** SCANLAN®  
**Gonzalez-Rivas Knot Pusher**  
 Developed in cooperation with Diego Gonzalez-Rivas, MD, FECTS

Cat. No.	Description	Shaft	Working Length	Total Length
<b>NEW</b> 9009-826-14	Curved U-tip	5 mm	10 1/2" (27 cm)	14 3/4" (37.5 cm)
<b>NEW</b> 9009-826-17			12 1/2" (32 cm)	16 3/4" (42.4 cm)

Please Note...  
 Each Scanlan instrument is individually handcrafted to provide the surgeon with the highest quality, longest-lasting, precision instrument possible.  
 Reflecting this unique process, all stated dimensions are approximate.

Please check with your Scanlan Representative for Firm Sale status. Custom modifications available upon request.  
 For a complete listing of models visit... [www.scanlaninternational.com](http://www.scanlaninternational.com)



# Knot Pushers

VATS / MIS

9009-827-11



**MIS** SCANLAN®  
**Chitwood Knot Pusher Mini "Trap Model"**  
 Developed in cooperation with W. Randolph Chitwood Jr. MDS

Cat. No.	Description	Suture Size	Shaft	Working Length	Total Length
9009-827-11	"Trap Model"	2-0 and Smaller	5 mm	5 1/8" (13 cm)	11" (28 cm)
9009-827-12				5 1/2" (14 cm)	12" (30.5 cm)
9009-827-13				6 3/4" (17 cm)	13 5/8" (34.6 cm)
9009-827-15				8 1/2" (21.5 cm)	15 3/8" (39.1 cm)

9009-828



**VATS** **MIS** SCANLAN®  
**Chitwood Knot Pusher Original "Trap Model"**  
 Developed in cooperation with W. Randolph Chitwood Jr. MD

Cat. No.	Description	Suture Size	Shaft	Working Length	Total Length
9009-828	Original "Trap Model"	2-0 and Smaller	5 mm	6 1/8" (15.5 cm)	12 1/2" (32 cm)
9009-828-15	Original "Trap Model"			8 1/2" (21.5 cm)	15 3/8" (39.1 cm)
9009-828-16	Original "Trap Model" Long Handle			7 1/4" (18.5 cm)	15 3/4" (40 cm)



9009-838SC

VATS / MIS



**VATS** **MIS** SCANLAN®  
**Chitwood Super Cut™ Suture Cutter**  
Developed in cooperation with W. Randolph Chitwood Jr. MD

Cat. No.	Description	Suture Size	Shaft	Working Length	Total Length
9009-838SC				7" (18 cm)	11" (28 cm)
9009-840SC	Trap Model™	2-0 and Smaller	5 mm	9" (23 cm)	13" (33 cm)
9009-842SC				11" (28 cm)	15" (38 cm)

Please Note...  
Each Scanlan instrument is individually handcrafted to provide the surgeon with the highest quality, longest-lasting, precision instrument possible.  
Reflecting this unique process, all stated dimensions are approximate.

Please check with your Scanlan Representative for Firm Sale status. Custom modifications available upon request.  
For a complete listing of models visit... [www.scanlaninternational.com](http://www.scanlaninternational.com)





Variable Suction Regulator  
9009-909 and 9009-911



6 mm Tip Diameter  
All Models



Suction tips are shown  
approximate size



SCANLAN®

## Wolf Suction Instrument

Developed in cooperation with Randall K. Wolf, MD

Cat. No.	Description	Shaft	Working Length	Total Length
9009-908	Curved blunt tip 6 mm width tip	3.2 mm	6 3/4" (17 cm)	12 1/4" (31 cm)
9009-909	Variable suction Curved blunt tip 6 mm width tip			
9009-910	Curved blunt tip 6 mm width tip		8 3/4" (22 cm)	14 1/4" (36 cm)
9009-911	Variable suction Curved blunt tip 6 mm width tip			
9009-912	Curved blunt tip 6 mm width tip	3.2 mm to 5 mm	8 3/4" (22 cm)	14 1/4" (36 cm)
9009-913	Variable suction Curved blunt tip 6 mm width tip			

**Please Note...**

Each Scanlan instrument is individually handcrafted to provide the surgeon with the highest quality, longest-lasting, precision instrument possible. Reflecting this unique process, all stated dimensions are approximate.

# Suction Instruments

9009-916

VATS / MIS



Variable Suction Regulator  
(9009-915 and 9009-917)



7.5 mm Tip Diameter  
(All Models)



Suction tips are shown  
approximate size



SCANLAN®  
**Dennis Suction Instrument**

Cat. No.	Description	Shaft	Working Length	Total Length
9009-914	Curved blunt tip 7.5 mm width tip	5 mm	8 3/4" (22 cm)	14 1/4" (36 cm)
9009-915	Variable suction Curved blunt tip 7.5 mm width tip			
9009-916	Curved blunt tip 7.5 mm width tip		12 1/2" (32 cm)	17 3/4" (45.5 cm)
9009-917	Variable suction Curved blunt tip 7.5 mm width tip			

Please check with your Scanlan Representative for Firm Sale status. Custom modifications available upon request.  
For a complete listing of models visit... [www.scanlaninternational.com](http://www.scanlaninternational.com)





5 mm Tip Diameter  
(9009-900 and 9009-901)

Variable Suction Regulator  
(9009-901)

Suction tips are shown  
approximate size



SCANLAN®

## D'Amico Suction Instrument

Developed in cooperation with Thomas A. D'Amico, MD

Cat. No.	Description	Shaft	Working Length	Total Length
9009-900	Straight blunt tip 5 mm width tip	5 mm	12 1/2" (32 cm)	17 3/4" (45.5 cm)
9009-901	Variable suction Straight blunt tip 5 mm width tip			

**Please Note...**

Each Scanlan instrument is individually handcrafted to provide the surgeon with the highest quality, longest-lasting, precision instrument possible. Reflecting this unique process, all stated dimensions are approximate.

Please check with your Scanlan Representative for Firm Sale status. Custom modifications available upon request.

For a complete listing of models visit... [www.scanlaninternational.com](http://www.scanlaninternational.com)

# Suction Instruments

9009-920

VATS / MIS



10 mm Tip Diameter  
(9009-920 and 9009-921)



Suction tips are shown  
approximate size

Variable Suction Regulator  
(9009-921)



**VATS** **MIS** SCANLAN®  
**D'Amico Suction Instrument**  
Developed in cooperation with Thomas A. D'Amico, MD

Cat. No.	Description	Shaft	Working Length	Total Length
9009-920	Straight blunt tip 10 mm width tip	10 mm	12 1/2" (32 cm)	17 3/4" (45.5 cm)
9009-921	Variable suction Straight blunt tip 10 mm width tip			
9009-924	Curved blunt tip 10 mm width tip			
9009-925	Variable suction Curved blunt tip 10 mm width tip			

SCANLAN®

## Suction Accessories

9009-905



**VATS** **MIS** SCANLAN®  
**Suction Accessories**

Cat. No.	Description	Total Length
9009-905	Brush set, pack of 10, for 5 mm D'Amico and 3.2 mm Wolf and Dennis suction instruments	19" (48.3 cm)
9009-922	Brush set, pack of 10, for 10 mm D'Amico suction instruments	



# Dennis Rib Cutter

VATS / MIS

9909-900



9909-900

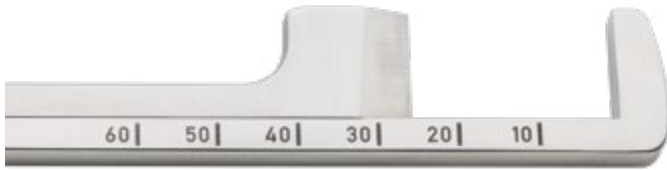

9909-902



9909-904

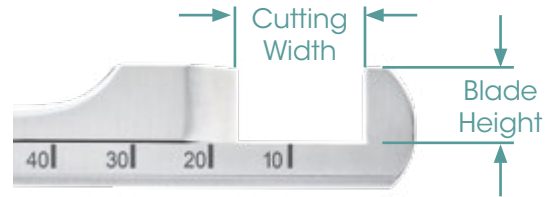

Cat. No.	Description	Cutting Width	Blade Height	Shaft	Working Length	Total Length
9909-900	Straight shaft	16 mm	10 mm	10 mm	11 1/2" (29 cm)	13 1/2" (34 cm)
9909-902	Straight shaft	25 mm	15 mm			
9909-904	Straight shaft	25 mm	20 mm			

**Please Note...**

Each Scanlan instrument is individually handcrafted to provide the surgeon with the highest quality, longest-lasting, precision instrument possible. Reflecting this unique process, all stated dimensions are approximate.



# Periosteal Elevator

9009-823-14

VATS / MIS



**VATS** SCANLAN®  
Periosteal Elevator

Cat. No.	Description	Working Length	Total Length
<b>NEW</b> 9009-823-14	Periosteal Elevator	10 3/4" (27.3 cm)	14 3/4" (37.5 cm)
<b>NEW</b> 9009-823-17		12 3/4" (32.5 cm)	16 3/4" (43.4 cm)

Please check with your Scanlan Representative for Firm Sale status. Custom modifications available upon request.  
For a complete listing of models visit... [www.scanlaninternational.com](http://www.scanlaninternational.com)



# Chest Tube Passer

VATS / MIS

4004-185



VATS
MIS
 SCANLAN®  
 Stern™ Chest Tube Passer

Cat. No.	Description	Shaft	Working Length	Total Length
4004-185	Without ratchet	10 mm	6 7/8" (17.5 cm)	9 3/4" (24.8 cm)
4004-186	With ratchet			
4004-189	Without ratchet		11" (28 cm)	14" (35.6 cm)

**Please Note...**

Each Scanlan instrument is individually handcrafted to provide the surgeon with the highest quality, longest-lasting, precision instrument possible. Reflecting this unique process, all stated dimensions are approximate.



# Suture Puller

9009-816

VATS / MIS

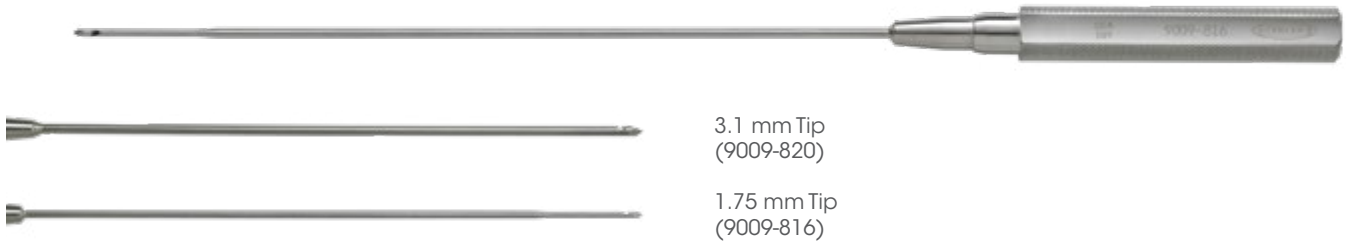

SCANLAN®

## Chitwood Suture Puller

Developed in cooperation with W. Randolph Chitwood Jr., MD

Cat. No.	Description	Shaft	Working Length	Total Length
9009-816	Straight 1.75 mm Tip	3.1 mm	7 1/2" (19 cm)	11 1/2" (29 cm)
9009-820	Straight 3.1 mm Tip			

Please check with your Scanlan Representative for Firm Sale status. Custom modifications available upon request.  
For a complete listing of models visit... [www.scanlaninternational.com](http://www.scanlaninternational.com)



VATS / MIS

